

Silicon NPN High Voltage Switching Transistor

Features

- Multi diffusion technology
- Glass passivation
- High reverse voltage
- Short switching times

Applications

Electronic lamp ballast circuits
Switch-mode power supplies

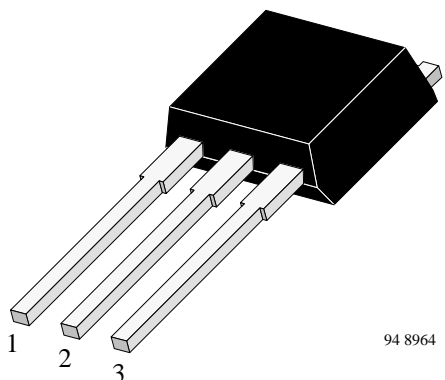

BUD86
BUD87
1 Emitter 2 Collector 3 Base

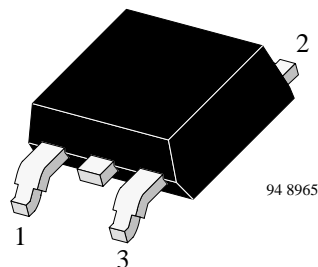

BUD86 –SMD
BUD87 –SMD
1 Emitter 2 Collector 3 Base

Absolute Maximum Ratings

$T_{case} = 25^{\circ}C$, unless otherwise specified

Parameter	Test Conditions	Type	Symbol	Value	Unit
Collector-emitter voltage		BUD86	V_{CEO}	400	V
		BUD87	V_{CEO}	450	V
		BUD86	V_{CES}	800	V
		BUD87	V_{CES}	1000	V
Emitter-base voltage			V_{EBO}	5	V
Collector current			I_C	0.5	A
Collector peak current			I_{CM}	1	A
Base current			I_B	0.3	A
			$-I_B$	0.3	A
Total power dissipation	$T_{case} \leq 60^{\circ}C$		P_{tot}	20	W
Junction temperature			T_j	150	$^{\circ}C$
Storage temperature range			T_{stg}	-65 to +150	$^{\circ}C$

Maximum Thermal Resistance

$T_{\text{case}} = 25^{\circ}\text{C}$, unless otherwise specified

Parameter	Test Conditions	Symbol	Value	Unit
Junction case		R_{thJC}	4.5	K/W

Electrical Characteristics

$T_{\text{case}} = 25^{\circ}\text{C}$, unless otherwise specified

Parameter	Test Conditions	Type	Symbol	Min	Typ	Max	Unit
Collector cut-off current	$V_{\text{CE}} = 800 \text{ V}$	BUD86	I_{CES}			100	μA
	$V_{\text{CE}} = 1000 \text{ V}$	BUD87	I_{CES}			100	μA
	$V_{\text{CE}} = 800 \text{ V}; T_{\text{case}} = 125^{\circ}\text{C}$	BUD86	I_{CES}			1	mA
	$V_{\text{CE}} = 1000 \text{ V}; T_{\text{case}} = 125^{\circ}\text{C}$	BUD87	I_{CES}			1	mA
Collector-emitter breakdown voltage (figure 1)	$I_{\text{C}} = 100 \text{ mA}; L = 125 \text{ mH}; I_{\text{measure}} = 50 \text{ mA}$	BUD86	$V_{(\text{BR})\text{CEO}}$	400			V
		BUD87	$V_{(\text{BR})\text{CEO}}$	450			V
Emitter-base breakdown voltage	$I_{\text{E}} = 1 \text{ mA}$		$V_{(\text{BR})\text{EBO}}$	5			V
Collector-emitter saturation voltage	$I_{\text{C}} = 100 \text{ mA}; I_{\text{B}} = 10 \text{ mA}$		V_{CEsat}			0.8	V
	$I_{\text{C}} = 200 \text{ mA}; I_{\text{B}} = 20 \text{ mA}$		V_{CEsat}			1	V
Base-emitter saturation voltage	$I_{\text{C}} = 200 \text{ mA}; I_{\text{B}} = 20 \text{ mA}$		V_{BEsat}			1	V
DC forward current transfer ratio	$V_{\text{CE}} = 5 \text{ V}; I_{\text{C}} = 50 \text{ mA}$		h_{FE}		50		
Gain bandwidth product	$I_{\text{C}} = 50 \text{ mA}; V_{\text{CE}} = 10 \text{ V}; f = 1 \text{ MHz}$		f_{T}		20		MHz

Switching Characteristics

$T_{\text{case}} = 25^{\circ}\text{C}$, unless otherwise specified

Parameter	Test Conditions	Type	Symbol	Min	Typ	Max	Unit
Resistive load (figure 2)							
Storage time	$I_{\text{C}} = 400 \text{ mA}; I_{\text{B1}} = 20 \text{ mA}; -I_{\text{B2}} = 40 \text{ mA}; V_{\text{S}} = 125 \text{ V}$		t_{s}			3.5	μs
Fall time				t_{f}		0.4	

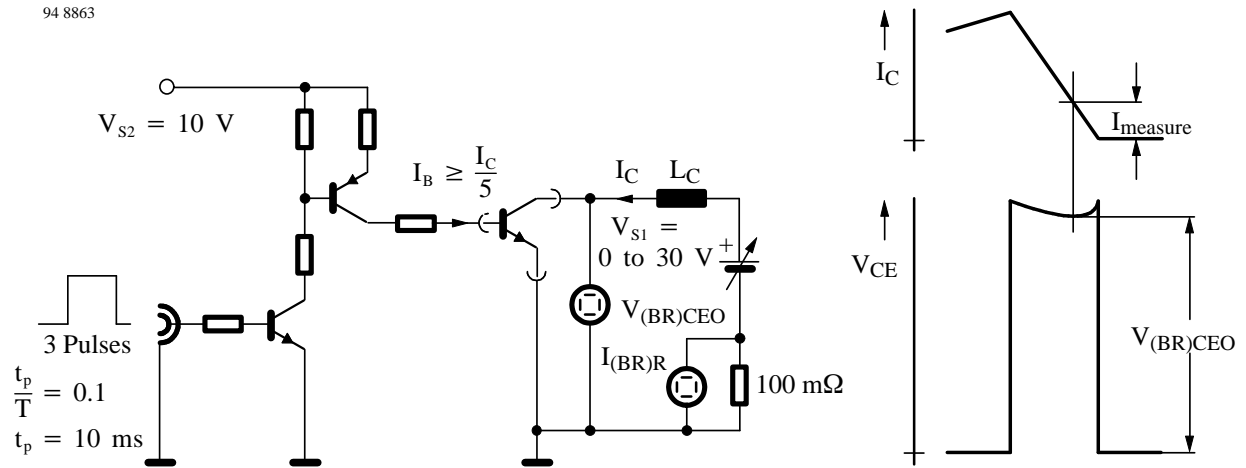

Figure 1. Test circuit for $V_{(BR)CEO}$

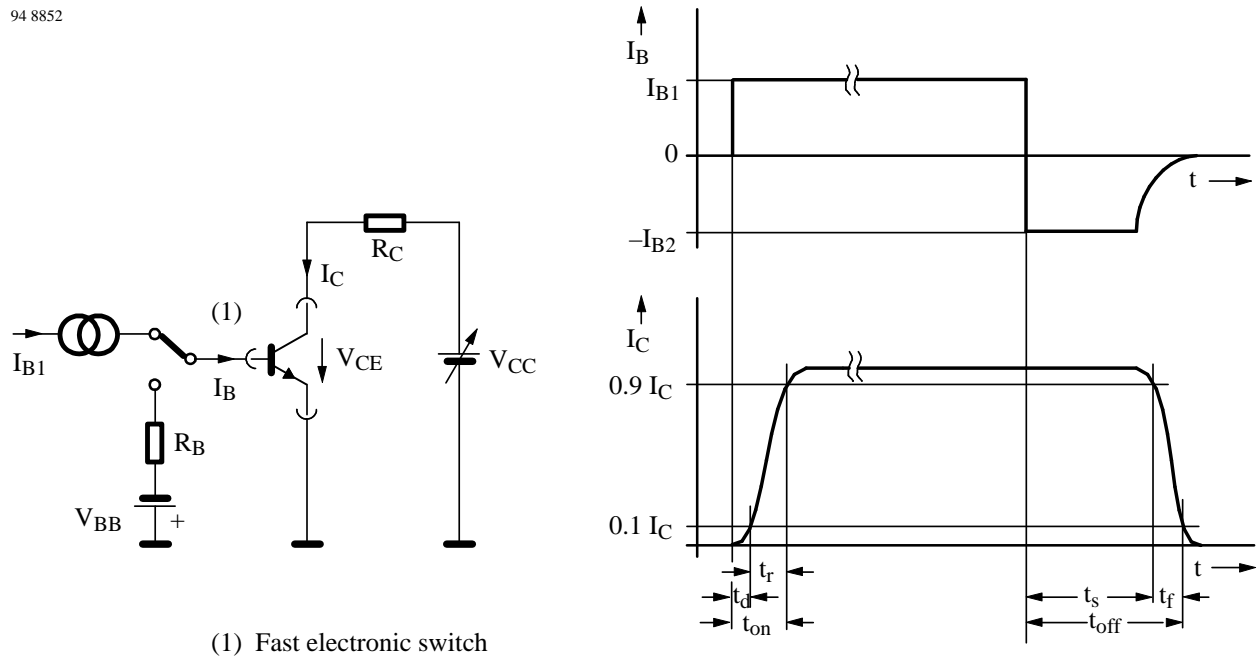

Figure 2. Test circuit for switching characteristics – resistive load

Typical Characteristics ($T_{case} = 25^{\circ}C$ unless otherwise specified)

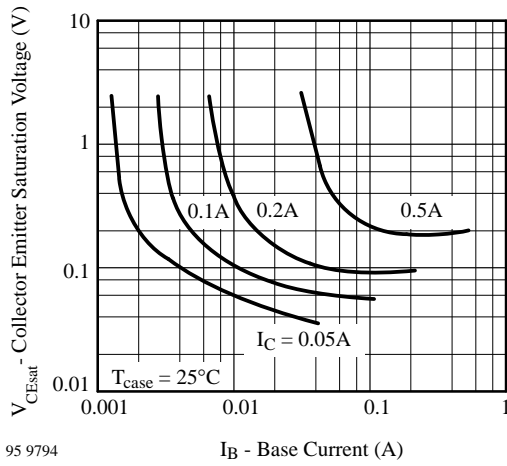

Figure 3. V_{CEsat} vs. I_B

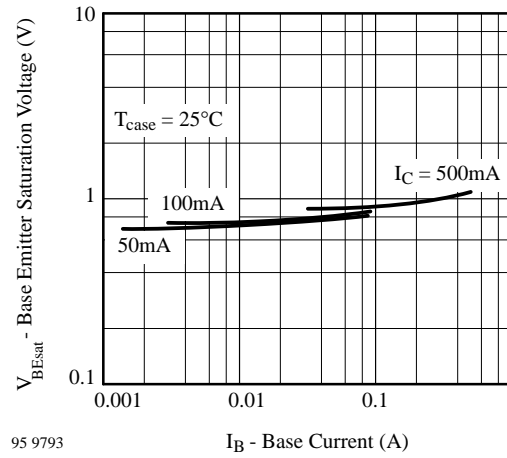

Figure 5. V_{BEsat} vs. I_B

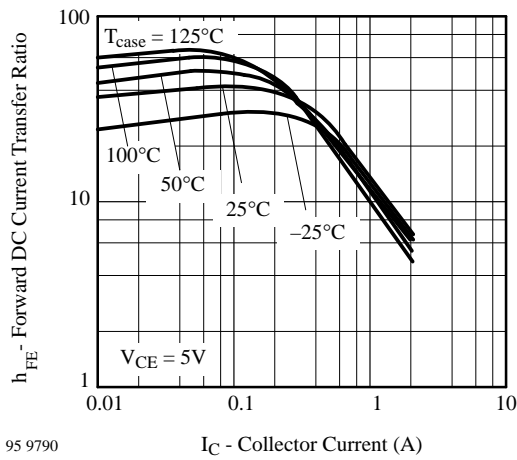

Figure 4. h_{FE} vs. I_C

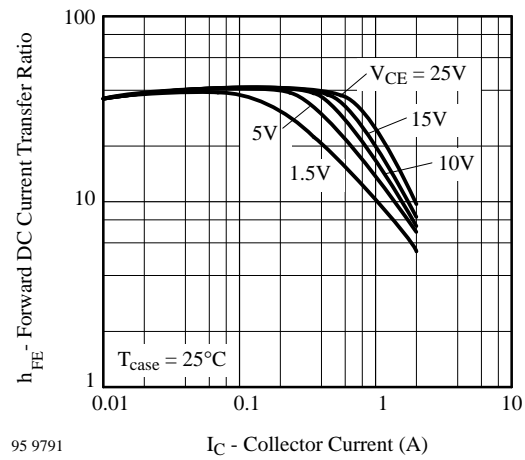



Figure 6. h_{FE} vs. I_C

Dimensions in mm

TO251

94 8966

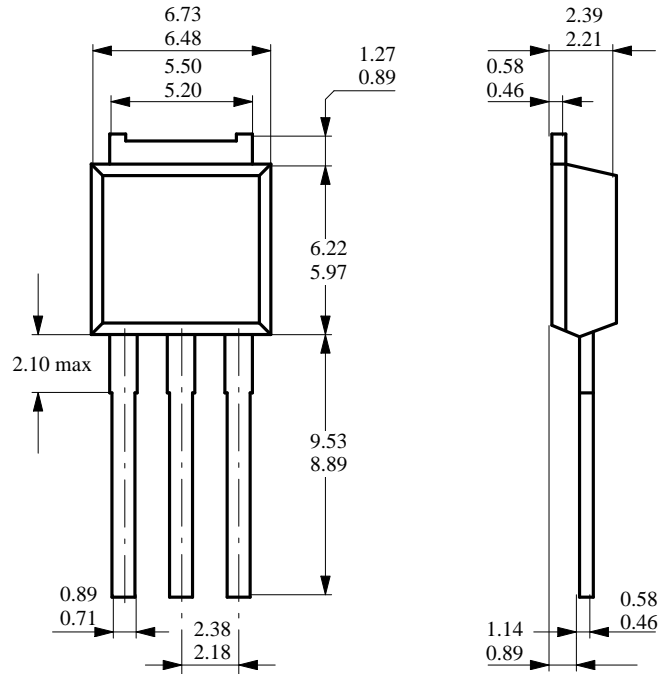

technical drawings
according to DIN
specifications



TO252

94 8967

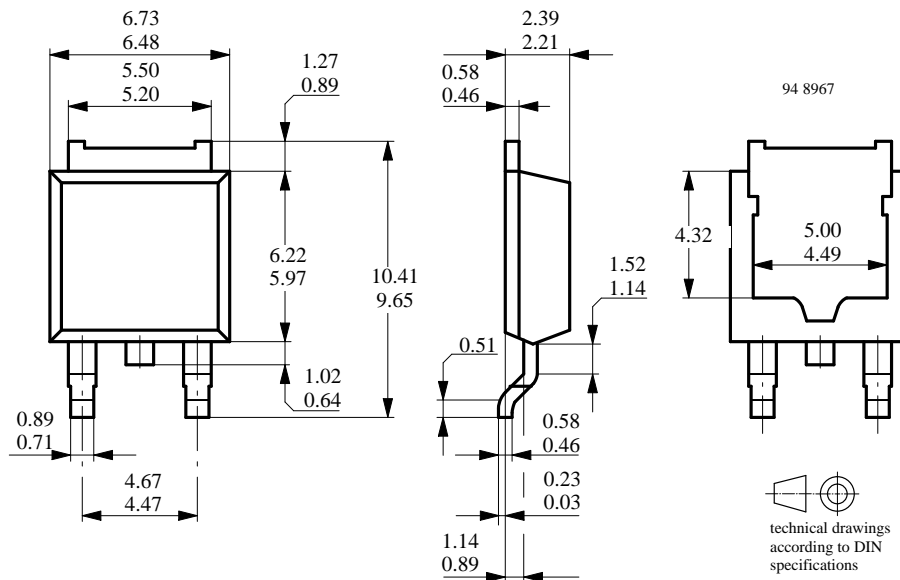
technical drawings
according to DIN
specifications



For ordering TO 252 add SMD to the type number (i.e. BUD86-SMD)

Ozone Depleting Substances Policy Statement

It is the policy of **TEMIC TELEFUNKEN microelectronic GmbH** to

1. Meet all present and future national and international statutory requirements.
2. Regularly and continuously improve the performance of our products, processes, distribution and operating systems with respect to their impact on the health and safety of our employees and the public, as well as their impact on the environment.

It is particular concern to control or eliminate releases of those substances into the atmosphere which are known as ozone depleting substances (ODSs).

The Montreal Protocol (1987) and its London Amendments (1990) intend to severely restrict the use of ODSs and forbid their use within the next ten years. Various national and international initiatives are pressing for an earlier ban on these substances.

TEMIC TELEFUNKEN microelectronic GmbH semiconductor division has been able to use its policy of continuous improvements to eliminate the use of ODSs listed in the following documents.

1. Annex A, B and list of transitional substances of the Montreal Protocol and the London Amendments respectively
2. Class I and II ozone depleting substances in the Clean Air Act Amendments of 1990 by the Environmental Protection Agency (EPA) in the USA
3. Council Decision 88/540/EEC and 91/690/EEC Annex A, B and C (transitional substances) respectively.

TEMIC can certify that our semiconductors are not manufactured with ozone depleting substances and do not contain such substances.

We reserve the right to make changes to improve technical design and may do so without further notice.

Parameters can vary in different applications. All operating parameters must be validated for each customer application by the customer. Should the buyer use TEMIC products for any unintended or unauthorized application, the buyer shall indemnify TEMIC against all claims, costs, damages, and expenses, arising out of, directly or indirectly, any claim of personal damage, injury or death associated with such unintended or unauthorized use.

TEMIC TELEFUNKEN microelectronic GmbH, P.O.B. 3535, D-74025 Heilbronn, Germany
Telephone: 49 (0)7131 67 2831, Fax number: 49 (0)7131 67 2423